



Owen Sound Drinking Water System



Annual Report 2022

Prepared by: Troy Pelletier- Water Treatment Superintendent

Contents

Section 1 – Drinking Water System General Information	3
Section 1.1 – Drinking Water System Description	4
Section 2 – Drinking Water Inspections and Audit Summaries	6
Section 3 – List of Water Treatment Chemicals Used:	6
Section 4 – Significant Costs Incurred	7
Section 5 – Adverse Water Quality Incidents reported	8
Section 6 – Microbiological Test Results	8
Section 7 – Operational Testing Results	9
Section 8 – Summary of Additional Testing	10
Section 9 – Inorganic and Organic Testing Summary	11
Section 10 – Summary of Lead Testing	13

Section 1 – Drinking Water System General Information

This report has been prepared in accordance with the reporting requirements set out in Ontario Regulation 170/03, Section 11 and as well as Schedule 22.

This report is to be presented to Council by the end of March each year. Copies of the report will be made available free of charge and can be found at the following locations;

- City Hall Clerk’s Office – located temporarily at 945 3rd Avenue East
- City’s website - <https://www.owensound.ca/en/city-hall/waterwastewater.aspx>
- Public Works office – 1900 20th Street East
- Water Treatment Plant – 2600 3rd Avenue East
- Owen Sound & North Grey Union Public Library – 824 1st Avenue West

Drinking Water System #	220001799
Drinking Water System Name	Owen Sound Drinking Water System
Drinking Water System Owner	Corporation of the City of Owen Sound
Drinking Water System Category	Large Municipal Residential
City of Owen Sound Population	22,000
Water Treatment Subsystem	Class 3, Certificate # 20 issued September 15th, 2005
Water Distribution Subsystem	Class 3, Certificate # 2094 issued September 15th, 2005
Drinking Water Works Permit #	092-202 Issue # 5 issued October 2nd, 2020
Municipal Drinking Water License	094-101 Issue # 5 issued October 2nd, 2020
Permit to Take Water #	3044-8SERHC issued March 23rd, 2012 expires March 15, 2022 P-300-8173611786 Issued May 28 th , 2022 Expires March 31 st , 2032
Period of Report	January 1, 2022 to December 31st, 2022

Other Drinking Water Systems that receive drinking water from the Owen Sound Drinking Water System are;

<u>Drinking Water System Owner</u>	<u>Drinking Water System #</u>
Municipality of Meaford (Leith)	260065312

A copy of this report will be provided to Meaford by the end of February.

Section 1.1 – Drinking Water System Description

The Richard H. Neath Water Purification plant is a direct filtration surface water treatment plant that draws its water from Georgian Bay. This plant serves a population of approximately 22,000 people.

The Water plant comprises of the following processes;

- Raw water screening (removal of larger debris, fish, etc.),
- Prechlorination (initial application of chlorine to the raw water),
- Zebra mussel control (chlorination at Intake during warmer months only, temperature above 10 degrees C),
- Flash mixing (initial addition of coagulant to the raw water through a rapid mixer),
- Coagulation/Flocculation (slower mixing of coagulant in larger tanks),
- UV disinfection (done just prior to water entering treated water wells),
- Post chlorination (adding of additional chlorine for the purpose of meeting CT requirements and having enough chlorine for water in the distribution system),
- Fluoridation (added in the two main treated water wells),
- Residue management tank for treating backwash wastewater. See Figure 1 below for a process schematic.

Figure 1

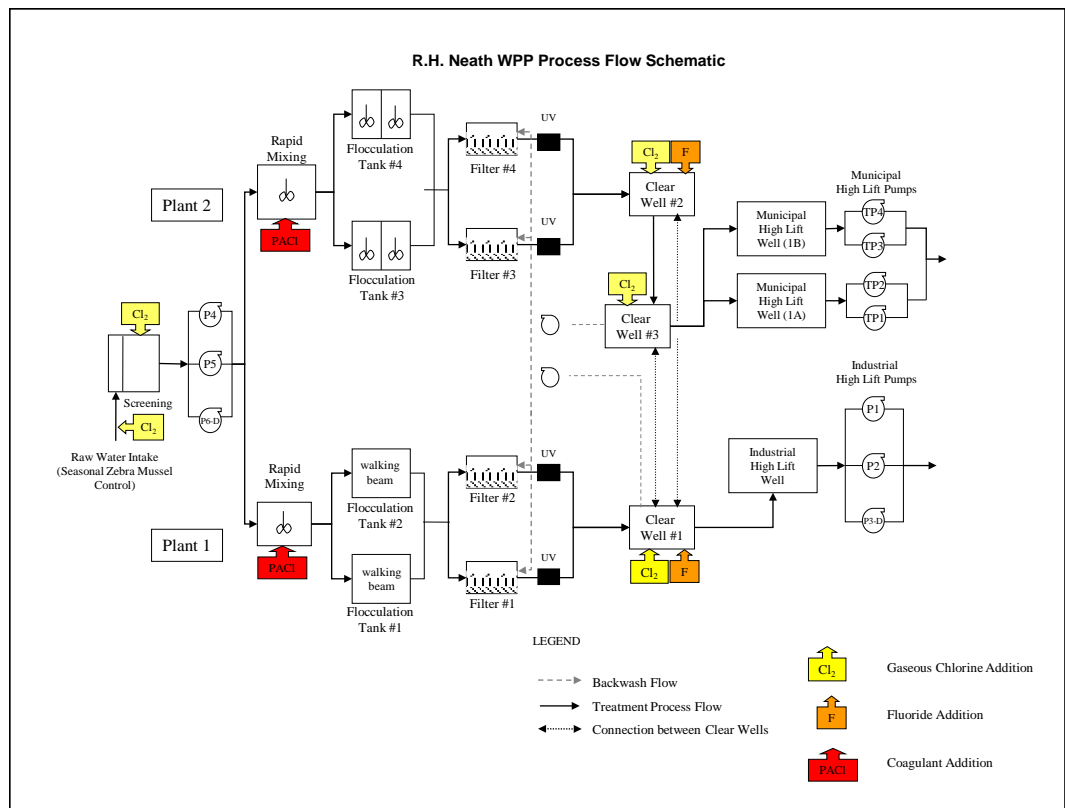

The City has a 22,000 m³ reservoir, 6 pressure zones (see Figure 2), 158.6 km of water mains, 11 pressure reducing /sustaining chambers, 10 check valve chambers, 673 City hydrants, 139 private hydrants, 64 flush hydrants/blow-offs/auto flushing units, and two booster stations that provides addition pressure in the Southeast and southwest portions of the City and outskirts.

Figure 2

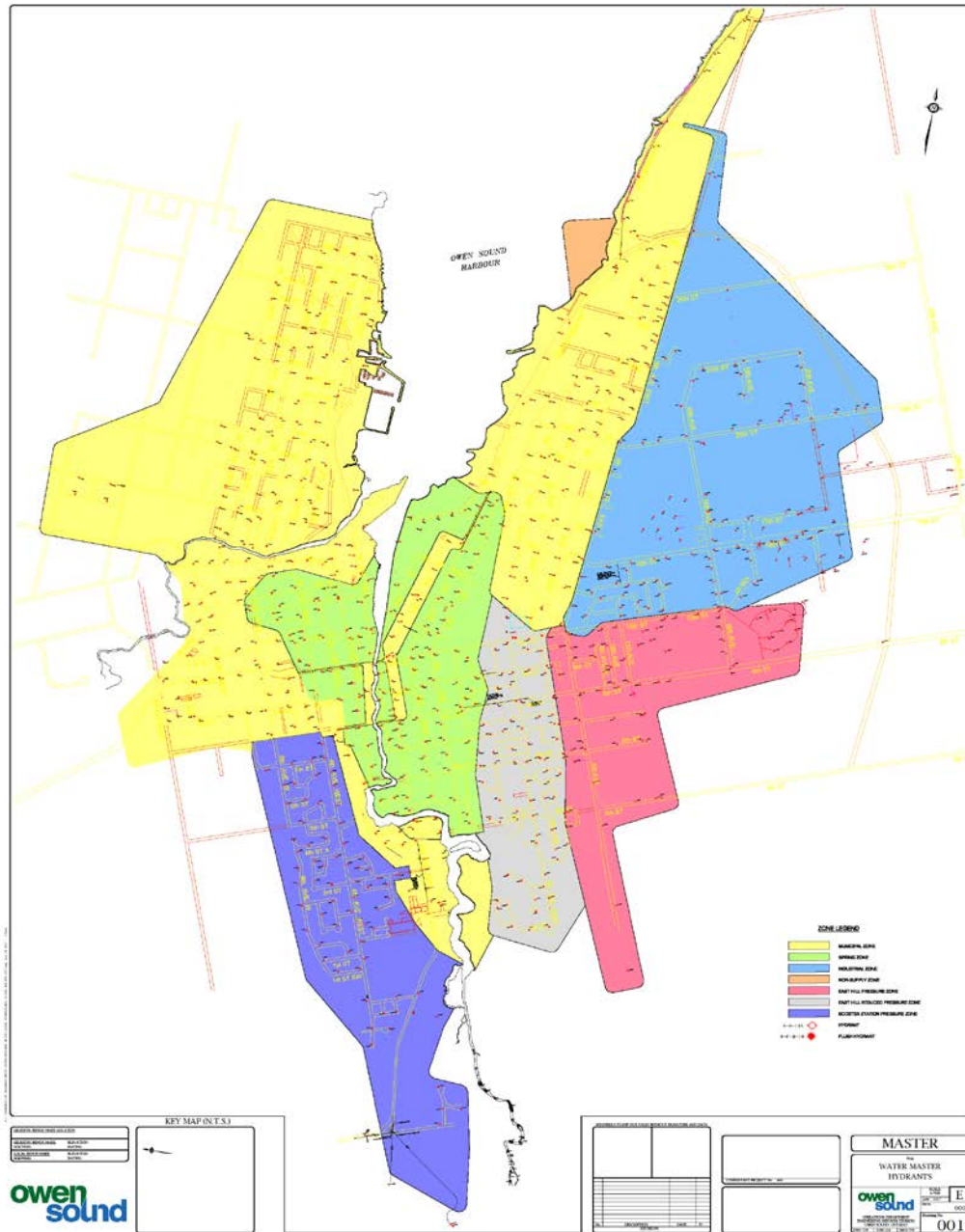

The City also has an additional agreement with the Municipality of Meaford to provide potable water to Leith from our boundary point on East Bayshore Rd.

Section 2 – Drinking Water Inspections and Audit Summaries

1. **Ministry of the Environment, Conservation and Parks (MECP) Inspection –**

During 2022, there was one MECP inspection completed in January 2022. There were four AWQI's during the review period (2021-2022). The City received 100.0% on the Inspection report card.

2. **Internal Audit/External Audit**

Internal Audit – Brigitte Roth, an independent auditor evaluated our Drinking Water Quality Management System (DWQMS) in December 2022. This consisted of a two day on-site visit reviewing all 21 elements of the DWQMS, interviewing water staff and testing their knowledge of the system.

There were two non-conformances identified, first, two items under Documents and Records Control (Element 5 of the DWQMS) and secondly, one item under Risk Assessment and Outcomes (Element 7 of the DWQMS).

The two items identified in the Documents and Records Control were related to the accessibility of documents and records, and secondly, there is a requirement in the DWQMS, that system infrastructure drawings are to be provided within a 12 month period, and this is not always the case. The item identified under the Risk Assessment and Outcomes was related to assessing potential hazards, in particular, a potential cyber security threat to the drinking water system. Plans to remediate these non-conformances are being reviewed and investigative and corrective measures are underway.

There were several opportunities for improvement (OFI's) identified in the audit also, and these are being reviewed.

External Audit – In April 2022, NSF International performed the external audit, and found no major non-conformances, one minor non-conformance, and three OFI's. The minor non-conformance was to develop a procedure for tracking and measuring continual improvement.

Section 3 – List of Water Treatment Chemicals Used:

1. **Chlorine Gas** (68 kg cylinders) – used in pre chlorination (treatment before filtration), and post chlorination (treatment after filtration).
2. **PAX XL-6** – is a coagulant used prior to filtration in the colder months (<10 degrees C). A coagulants primary objective is to adhere to suspended particulates, make them bigger in size, so to allow a higher removal rate of particulates in the filtration process.

3. **PAX XL-1900** – is a coagulant used prior to filtration in the warmer months (>10 degrees C). A coagulant's primary objective is to adhere to suspended particulates, make them bigger in size, so to allow a higher removal rate of particulates in the filtration process.
4. **Sodium Bisulphite** – is a chemical used in the process to remove chlorine from water for the purpose of reintroducing water back to the source, Georgian Bay. It is also used when filters are being prepared for use after a backwash called the ripening process.
5. **Polymer** – A polymer is used during a filter backwash to settle suspended particles in the wastewater detention tank, so they can be pumped to the sanitary system to be treated at the wastewater plant.

Section 4 – Significant Costs Incurred

Significant costs are costs associated with new equipment purchased, installed, repaired, or replaced;

Water Treatment

Item	Description	Cost (\$)
UV Bulbs	UV Lamps for 4 UV reactors.	\$17,000
Chlorine Gas Equipment	2 x Vacuum Regulators	\$7,000
Pressure Relief Valve (PRV)	New PRV for East Hill Pump Station	\$10,000
Diesel Generator and Diesel Pump	Annual Servicing and Load Bank Testing	\$9,150
Capital Project - Flocculator	Replaced with Flocculator drive	\$26,000
Capital Project- SCADA Upgrade	Remote PLC – Leith Boundary	\$40,000
Capital Project – Filter Upgrade	Filter Upgrade consisting of new underdrains, air scour technology, new media, new backwash pumps, and some piping upgrades – Multi year project – Completion date Mid 2024, This is a \$4,000,000 project.	\$91,000

Water Distribution

Item	Description	Cost (\$)
Capital Work - 16 th Street East Rehab	Rehabilitation of 16 th Street East and Road Reconstruction – Water costs only	\$695,000
Capital Work – Bayshore Road	5 Hydrants, and 5 services	\$108,500
Broken Watermains	25 broken watermains occurred, estimated repair at \$6,000 each	\$150,000
Capital Work – Cathodic Protection	New cathodic protection installed throughout the City.	\$325,000

Section 5 – Adverse Water Quality Incidents reported

#	Reporting Date	AWQI #	Adverse Location	Adverse Parameter	Adverse Result	Units	Remedial Action
	31-Mar	158096	Water Treatment Plant	Coagulant pump failure	n/a	n/a	Pump tubing failed. Replaced tubing and started system back up again.
	10-May	158354	Stone Tree Golf Course	Low Pressure	<20	psi	Low pressure caused by multiple main breaks. Pressure restored after main breaks repaired.

Section 6 – Microbiological Test Results

Microbiological testing done as required in Ontario Regulation 170/03 Schedule 10;

Location	Number of Samples	Range of E.coli Or Fecal Results (min #)- (max #)	Range of Total Coliform Results (min #)- (max #)	Number of HPC Samples	Range of HPC Results (min #)- (max #)
Raw	53	0 – 20	0-1620	n/a	n/a
Treated	53	0-0	0-0	53	<10- 20
Distribution	465	0-0	0-0	116	<10- >2000

Section 7 – Operational Testing Results

Operational testing done as required in Ontario Regulation 170/03 Schedule 7;

Parameter	Number of Grab Samples	Range of Results (min #) - (max #)
Filter 1 Turbidity	8760	0.02 NTU – 0.32 NTU
Filter 2 Turbidity	8760	0.01 NTU – 0.28 NTU
Filter 3 Turbidity	8760	0.01 NTU – 0.35 NTU
Filter 4 Turbidity	8760	0.02NTU – 2.51 NTU * The high value was caused by a momentary spike. Was over 1 NTU for only 3 minutes, 24 seconds.
Post 1 Chlorine	8760	0.24 – 3.38 * low occurred on October 24 th ,and was caused by a sample pump failure.
Post 2 Chlorine	8760	0.00 – 5.00 * low was caused by a sample pump failure of the chlorine analyzer on December 5 th , and the High level occurred on August 17 th , during a backwash, was only over 5 mg/L for just under 5 minutes.
Municipal Chlorine	8760	1.25 – 2.26
Industrial Chlorine	8760	0.66 – 2.42
Municipal Fluoride	8760	0.38 – 1.05
Industrial Fluoride	8760	0.24 – 0.85

Note: Unit of measurement is in milligrams per litre (mg/L), unless stated otherwise. The number of grab samples is expressed in hours/year, equivalent to continuous monitoring.

Section 8 – Summary of Additional Testing

A summary of additional testing and sampling carried out by an approval, order, or other legal instrument.

Legal Document	Date of Legal Instrument Issued	Parameter	Date Sampled	Result	Unit of Measure
Municipal License # 094-101	October 2 nd , 2020	Chlorine – Wastewater System	06-Jan	0.00	mg/L
Municipal License # 094-101	October 2 nd , 2020	Aluminum	13-Jan	0.070	mg/L
Municipal License # 094-101	October 2 nd , 2020	Chlorine – Wastewater System	02-Feb	0.00	mg/L
Municipal License # 094-101	October 2 nd , 2020	Total Suspended Solids	02-Feb	17	mg/L
Municipal License # 094-101	October 2 nd , 2020	Chlorine – Wastewater System	03-Mar	0.00	mg/L
Municipal License # 094-101	October 2 nd , 2020	Chlorine – Wastewater System	01-Apr	0.00	mg/L
Municipal License # 094-101	October 2 nd , 2020	Aluminum	11-Apr	0.077	mg/L
Municipal License # 094-101	October 2 nd , 2020	Total Suspended Solids	2-May	7	mg/L
Municipal License # 094-101	October 2 nd , 2020	Chlorine – Wastewater System	2-May	0.00	mg/L
Municipal License # 094-101	October 2 nd , 2020	Chlorine – Wastewater System	01-Jun	0.00	mg/L
Municipal License # 094-101	October 2 nd , 2020	Chlorine – Wastewater System	06-Jul	0.00	mg/L
Municipal License # 094-101	October 2 nd , 2020	Aluminum	11-Jul	0.133	mg/L
Municipal License # 094-101	October 2 nd , 2020	Total Suspended Solids	2-Aug	3.6	mg/L
Municipal License # 094-101	October 2 nd , 2020	Chlorine – Wastewater System	02-Aug	0.00	mg/L
Municipal License # 094-101	October 2 nd , 2020	Chlorine – Wastewater System	06-Sep	0.00	mg/L
Municipal License # 094-101	October 2 nd , 2020	Chlorine – Wastewater System	03-Oct	0.00	mg/L
Municipal License # 094-101	October 2 nd , 2020	Aluminum	11 Oct	0.024	mg/L
Municipal License # 094-101	October 2 nd , 2020	Chlorine – Wastewater System	2-Nov	0.00	mg/L
Municipal License # 094-101	October 2 nd , 2020	Total Suspended Solids	2-Nov	8.8	mg/L
Municipal License # 094-101	October 2 nd , 2020	Chlorine – Wastewater System	2-Dec	0.00	mg/L

Section 9 – Inorganic and Organic Testing Summary

Under Ontario Regulation 170/03, Schedule 13, 13-2 and 13-4 are required to be sampled annually.

Inorganic Parameters

Parameter	Sample Date	Result Value	Unit of Measure	MAC Level	1/2 MAC Level	Exceedance
Antimony	11-Jan	<0.00006	mg/L	0.006	0.003	No
Arsenic	11-Jan	0.0002	mg/L	0.025	0.0125	No
Barium	11-Jan	0.0123	mg/L	1.0	0.5	No
Boron	11-Jan	0.013	mg/L	5.0	2.5	No
Cadmium	11-Jan	<0.000003	mg/L	0.005	0.0025	No
Chromium	11-Jan	0.00014	mg/L	0.05	0.025	No
Mercury	11-Jan	<0.00001	mg/L	0.001	0.0005	No
Selenium	11-Jan	0.00011	mg/L	0.01	0.005	No
Sodium	5-Feb-18	5.6	mg/L	>20	>10	No
Uranium	11-Jan	0.000131	mg/L	0.02	0.01	No
Fluoride – Municipal	31-Dec	0.64	mg/L	1.50	n/a	No
Fluoride - Industrial	31-Dec	0.63	mg/L	1.50	n/a	No
Nitrite	11-Oct	<0.003	mg/L	1.0	0.5	No
Nitrate	11-Oct	0.233	mg/L	10.0	5.0	No

Note: Unit of measurement is in milligrams per litre (mg/L), unless stated otherwise.

Organic Parameters

Parameter	Sample Date	Result Value	Unit of Measure	MAC Level	1/2 MAC Level	Over MAC?
Aalachlor	11-Jan	<0.00002	mg/L	0.005	0.0025	No
Atrazine + N-dealkylated metabolites	11-Jan	<0.00001	mg/L	0.009	0.0045	No
Azinphos-methyl	11-Jan	<0.00005	mg/L	0.005	0.0025	No
Benzene	11-Jan	<0.00032	mg/L	0.001	0.0005	No
Benzo(a)pyrene	11-Jan	<0.000004	mg/L	0.00001	0.000005	No
Bromoxynil	11-Jan	<0.00033	mg/L	0.005	0.0025	No
Carbaryl	11-Jan	<0.00005	mg/L	0.09	0.045	No
Carbofuran	11-Jan	<0.00001	mg/L	0.09	0.045	No
Carbon Tetrachloride	11-Jan	<0.00017	mg/L	0.002	0.001	No
Chlorpyrifos	11-Jan	<0.00002	mg/L	0.09	0.045	No
Diazinon	11-Jan	<0.00002	mg/L	0.02	0.01	No

Dicamba	11-Jan	<0.0002	mg/L	0.12	0.06	No
1,2-Dichlorobenzene	11-Jan	<0.00041	mg/L	0.2	0.1	No
1,4-Dichlorobenzene	11-Jan	<0.00036	mg/L	0.005	0.0025	No
1,2-Dichloroethane	11-Jan	<0.00035	mg/L	0.005	0.0025	No
1,1-Dichloroethylene (vinylidene chloride)	11-Jan	<0.00033	mg/L	0.014	0.007	No
Dichloromethane	11-Jan	<0.00035	mg/L	0.05	0.025	No
2-4 Dichlorophenol	11-Jan	<0.00015	mg/L	0.9	0.45	No
2,4-Dichlorophenoxy acetic acid (2,4-D)	11-Jan	<0.00019	mg/L	0.1	0.05	No
Diclofop-methyl	11-Jan	<0.0004	mg/L	0.009	0.0045	No
Dimethoate	11-Jan	<0.00006	mg/L	0.02	0.01	No
Diquat	11-Jan	<0.001	mg/L	0.07	0.035	No
Diuron	11-Jan	<0.00003	mg/L	0.15	0.075	No
Glyphosate	11-Jan	<0.001	mg/L	0.28	0.14	No
Malathion	11-Jan	<0.00002	mg/L	0.19	0.095	No
MCPA	11-Jan	<0.00012	mg/L	0.1	0.05	No
Metolachlor	11-Jan	<0.00001	mg/L	0.05	0.025	No
Metribuzin	11-Jan	<0.00002	mg/L	0.08	0.04	No
Monochlorobenzene	11-Jan	<0.0003	mg/L	0.08	0.04	No
Paraquat	11-Jan	<0.001	mg/L	0.01	0.005	No
Pentachlorophenol	11-Jan	<0.00015	mg/L	0.06	0.03	No
Phorate	11-Jan	<0.00001	mg/L	0.002	0.001	No
Picloram	11-Jan	<0.001	mg/L	0.19	0.095	No
Polychlorinated Biphenyls(PCB)	11-Jan	<0.00004	mg/L	0.003	0.0015	No
Prometryne	11-Jan	<0.00003	mg/L	0.001	0.0005	No
Simazine	11-Jan	<0.00001	mg/L	0.01	0.005	No
THM (latest annual average)	2022	0.033	mg/L	0.100	0.05	No
Terbufos	11-Jan	<0.00001	mg/L	0.001	0.0005	No
Tetrachloroethylene	11-Jan	<0.00035	mg/L	0.01	0.005	No
2,3,4,6-Tetrachlorophenol	11-Jan	<0.0002	mg/L	0.10	0.05	No
Triallate	11-Jan	<0.00001	mg/L	0.23	0.115	No
Trichloroethylene	11-Jan	<0.00044	mg/L	0.005	0.0025	No
2,4,6-Trichlorophenol	11-Jan	<0.00025	mg/L	0.005	0.0025	No
Trifluralin	11-Jan	<0.00002	mg/L	0.045	0.0225	No

Vinyl Chloride	11-Jan	<0.00017	mg/L	0.001	0.0005	No
Haloacetic Acids (latest annual average)	2022	0.0183	mg/L	0.08	.04	No

List of any Inorganic and Organic parameter(s) that exceeded half of the standard prescribed in Schedule 2 of the Ontario Drinking Water Standards

*Nothing to report at this time.

Section 10 – Summary of Lead Testing

Lead testing is required as per Ontario Regulation 170/03, Schedule 15.1, and requires Municipalities to sample in areas that have a potential for higher lead levels. This testing consists of Lead, pH, and Alkalinity at 4 sites, and is completed twice per year. Since Owen Sound has no known Lead services since 2012, a reduced sampling program has been approved by the MECP, which only requires testing of the distribution system for Lead every third year.

Lead testing was not required in 2022.

Location Type	# of Samples	Range of Lead Results (min#) – (max #)	# of Exceedances
Plumbing	n/a	n/a	n/a
Distribution	n/a	n/a	n/a